

How to present pure-tone infrasound to the ear

Holger JOOST¹; Björn FRIEDRICH²; Jesko L. VERHEY²; Thomas FEDTKE¹

¹ Physikalisch-Technische Bundesanstalt, Braunschweig, Germany

² Otto von Guericke University Magdeburg, Germany

ABSTRACT

An increasing number of individuals are being exposed to infrasound. It is, however, still not clear, how infrasound is perceived by human beings. Regarding auditory perception, one hypothesis is that non-linear processes within the ear generate distortion products that make infrasound audible. To investigate this hypothesis, it is crucial to rule out that such distortions were produced technically, i.e., by the stimulus presentation system rather than the auditory system. This paper introduces a compact, low-distortion infrasound system, based on a commercially available audiometric earphone, for simultaneous presentation of pure-tone infrasound and audio sound to the ear via an ear insert. This system also allows for the recording of sound in the ear canal during signal presentation. Performance characteristics of the system for the stimulus presentation and the sound recording units are presented. It is shown that the interaction of infrasound and audio sound, such as modulation of the audio sound by the infrasound, is negligible with respect to auditory perception.

Keywords: infrasound stimulus system, ear insert, acoustic distortions, sound recording in the ear canal

1. INTRODUCTION

Infrasound is commonly defined as sound with frequencies below 20 Hz (1). Although the term infrasound insinuates that these frequencies are outside the audible range, there is some evidence that the human auditory system is sensitive to infrasound down to 2 Hz (2, for a review; 3). Yet, the knowledge about the underlying mechanisms is still vague. One hypothesis is that (*per se* inaudible) internal sounds in the audio-frequency range produced by physiological processes, such as blood flow, are modulated by infrasound, making the latter audible (4). An alternative hypothesis is that non-linear processes within the cochlea produce audible distortion products in the audio-frequency range (5). In order to investigate whether non-linear processes within the ear play a role in infrasound perception, it is crucial that the system used for the presentation of the infrasound generates as little harmonic distortions as possible. Thus, the main aim of the present study was to develop a sound reproduction system that can generate sufficiently high sound pressure levels and, at the same time, has distortion component levels well below the threshold in quiet at these frequencies. The second aim was to incorporate into the system a microphone that monitors the sound in the ear and detects possible distortions. To this end, it was investigated if a system that was initially developed to measure otoacoustic emissions (OAE, 6) in the ear canal can be used when infrasound is presented.

2. INFRASOUND REPRODUCTION AND ANALYSIS SYSTEM

2.1 Requirements for the sound reproduction and the in-ear sound measuring system

In order to investigate the infrasound perception by the auditory system it is mandatory that the sound is only delivered to the ear. The system should allow for presenting (sinusoidal) infrasound (IS) signals as well as sounds with frequencies in spectra in the audio sound (AS) range from 20 Hz to 4 kHz. The system should be able to deliver sounds up to sound pressure levels (SPL) that are equivalent to a loudness level of 40 phon (2). Note that, at low frequencies, these levels are quite high.

¹ holger.joost@ptb.de

Frequencies down to 4 Hz should be presented at this loudness level. At 4 Hz, this is equivalent to an SPL of 121.3 dB. It should also be possible to present combinations of IS+IS and IS+AS stimuli to the ear. This simultaneous presentation should not generate distortions. Since a simultaneous presentation of sound combinations by a single transducer might produce distortion from its non-linear behavior, the system should incorporate two separate low-distortion transducers for infrasound and audio sound. Many researchers working on the effect of infrasound on the human auditory system used the audiometric earphone transducer Beyerdynamic DT48 (Beyerdynamic, Germany) as an infrasound reproduction system. However, the DT48 is no longer commercially available. Thus, a new infrasound source with at least equivalent performance is required.

In addition to a high-quality sound reproduction system, a low-noise ear canal sound measuring system with a high sensitivity is necessary, which is not affected by high infrasound pressure levels to monitor the sound in the ear canal.

2.2 Sound reproduction system

Figure 1 shows a photograph of the sound reproduction system. It includes two RadioEar DD45 (RadioEar, USA) audiometric earphone transducers. It is an electrodynamic sound transducer specified by the manufacturer to have a nominal impedance of 10 Ω and to be linear up to an input power of 500 mW. The harmonic distortions are below 1% at 120 dB SPL. The two DD45 earphone transducers were mounted in air-sealed aluminum housings, each with a sound outlet in the front plate. Sound tubes with a length of 25 cm connect the sound outlets to the Etymotic ER-10B+ low-noise microphone system (Etymotic Research Inc., USA), which was initially developed for measurements of distortion product otoacoustic emissions (DPOAE). It was chosen for this study, because it allows for coupling external transducers as sound sources (see Figure 1). In addition, it ensures that the sound is only fed into the ear canal.



Figure 1 – Photograph of the sound reproduction system consisting of two DD45 earphone transducers (top left) coupled with the Etymotic ER-10B+ system (bottom right) via two tubes.

The volume that is enclosed by the membrane of the earphone transducers, the tubes, and the ear is small. It acts as a pressure chamber for low frequencies, enabling acoustic stimulation with the DD45 earphone transducers down to the infrasound frequency range. As requested (see Section 2.1), the two DD45 transducers offer the possibility of separated generation of audio sound and infrasound or of two independent infrasound stimuli.

Another essential part of the sound reproduction system is the headphone amplifier. To drive the DD45 transducer, a dual-channel headphone amplifier was built, based on an LPA-2S board (Funk Tonstudioteknik, Germany), that the manufacturer modified for our special purpose of driving this low-impedance (10 Ω) headphone transducer down to 2 Hz with a maximum power of 500 mW. This headphone amplifier offers high output power combined with very low noise floor and very low harmonic distortion (THD+N: 1-kHz signal 0.0013 %; 10-Hz signal 0.0006 %; both at 500mW/10 Ω).

2.3 Setup for analyzing the system performance

The system performance of the sound reproduction system and the Etymotic ER-10B+ low-noise microphone probe was analyzed within the setup shown in Figure 2. The sound emitted from the DD45 earphone transducers is guided through the sound tubes to the Etymotic ER-10B+ ear insert. The ear insert is connected to an occluded-ear simulator B&K 4157 (Brüel & Kjær, Denmark) by using the

adapter DB-2012, which simulates the whole external ear canal. The signal of the ear simulator microphone is amplified by the preamplifier B&K 2669, forwarded to the microphone conditioning amplifier B&K Nexus 2690, and, finally, to one channel of the APx555 audio analyzer (Audio Precision, USA). The Etymotic ER-10B+ microphone signal is amplified and conditioned by the provided microphone preamplifier, the signal of which is forwarded to the other channel of the APx555 audio analyzer. The APx555 audio analyzer serves not only as a signal analyzer but is also used as a high-precision generator of the pure-tone test signals, which are fed into the dual-channel earphone amplifier Funk LPA-2S driving the two DD45 transducers.

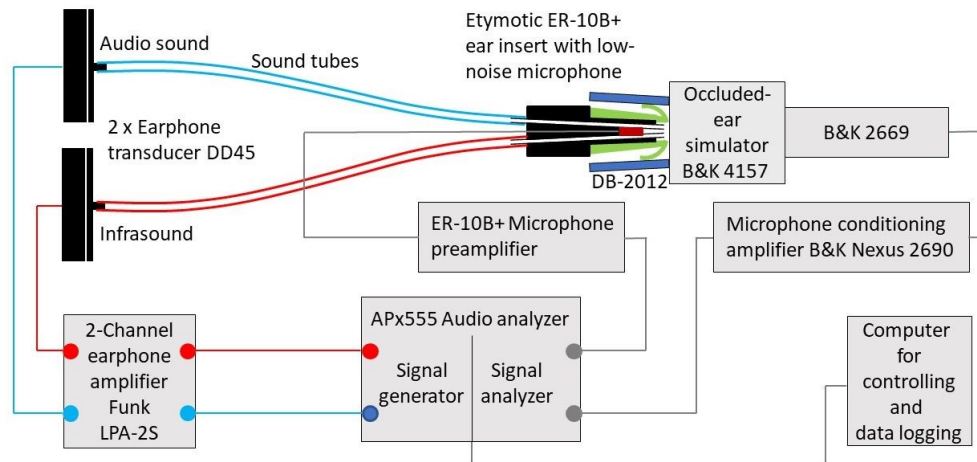

Figure 2 – Block diagram of the sound reproduction and performance analysis system.

Note that IEC 60318-4 specifies the occluded-ear simulator B&K 4157 only in the frequency range from 100 Hz to 10 kHz. For analyzing the system performance down to infrasound frequencies, however, the ear simulator had to be validated for frequencies below 100 Hz. In particular, a low-frequency level drop-off caused by the pressure equalization needed to be ruled out. The system was compared to a closed coupler (no vent) with identical effective volume, where a B&K 4193 infrasound microphone is used. This comparison revealed that differences are less than 0.7 dB in the frequency range from 2 Hz to 100 Hz (not shown). Hence, the B&K 4157 occluded-ear simulator can be used down to 2 Hz.

For all measurements, the acoustic parts of the setup (from the two DD45 earphone transducers to the ear-simulator B&K 4157) were placed in an anechoic test chamber (B&K 4222) to reduce background noise.

3. SYSTEM PERFORMANCE - RESULTS AND DISCUSSION

3.1 Single pure-tone infrasound

The top panel of Figure 3 shows the measured sound pressure level magnitude spectrum of a 4-Hz pure tone acoustically presented through the RadioEar DD45 transducer at 40 phon (red curve). In addition, a spectrum of a recording without pure-tone stimulus is shown in blue. In both spectra, the same peaks can be observed at 3.7 Hz and harmonics of this frequency. These are caused by the display refresh process of the B&K Nexus 2690 microphone-conditioning amplifier. In addition, peaks at 150 Hz, 250 Hz, and 350 Hz are observed that are resulting from electromagnetic interference of the 50-Hz power line frequency. The peak at about 84 Hz is of unknown origin. Since it is observed with and without stimulus, it is probably an environmental background signal. The spectrum of the sound presented through the DD45 earphone transducer reveals two prominent upper harmonics. The level of the first harmonic is 65 dB lower than that of the 4-Hz component. This component should be inaudible since it is 45 dB lower than the infrasound threshold reported by Moeller and Pedersen (2). The level of the second harmonic is even 20 dB lower than that of the first one and is, thus, also inaudible, as well as all other higher harmonics.

For comparison, the spectrum was also recorded when the sound is presented through a Beyerdynamic DT48 earphone transducer under the same conditions as for the DD45. For that purpose,

the two DD45 transducers in our measuring setup were replaced by two DT48 transducers, modified with air-sealed mounted front plates with sound outlets for the sound tubes. The LPA-2S headphone amplifier was able to drive the DT48 transducer with similar low noise and distortion as the DD45, despite its even lower impedance of 5Ω . This was proven by comparing the frequency spectra of the transducer terminal voltages of the two earphone types. In the bottom panel of Figure 3, the measured spectrum is shown (black curve). Also the DT48 earphone shows two prominent upper harmonics. However, the level of the first harmonic is only 45 dB lower than the level of the 4-Hz component and only 25 dB lower than the infrasound threshold. These values are about 20 dB higher than those of the DD45. Moreover, the DT48 produces pronounced higher harmonics up to the audio frequency range, with levels close to the hearing threshold. Since this threshold represents a median value and some individuals can detect signals that are several decibels lower than normal threshold, these higher harmonics produced by the DT48 may be detected by some of the listeners.

The RadioEar DD45 shows remarkably low harmonic distortions, with levels of more than 45 dB below the hearing threshold. This is sufficient to rule out any notable influence of distortions produced by the sound reproduction system on signal detection. Furthermore, the DD45 shows considerably fewer distortions than the often used Beyerdynamic DT48.

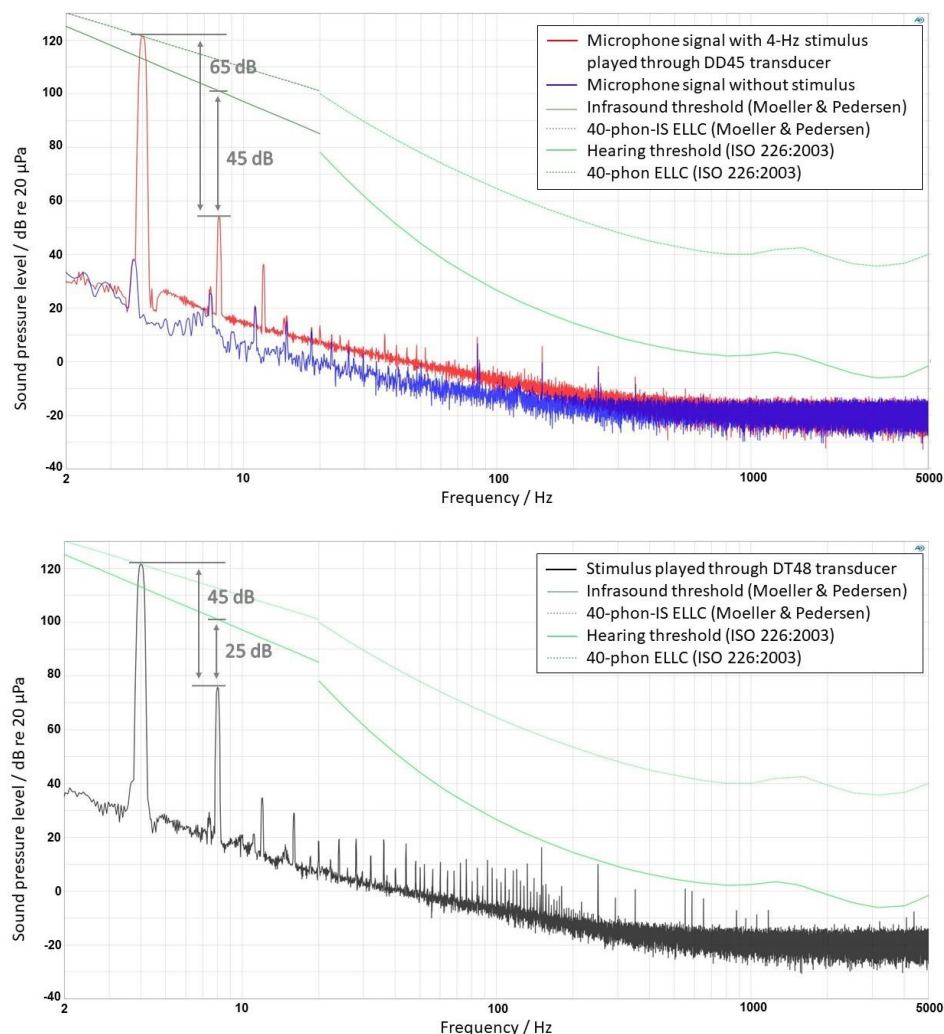

Figure 3 – Spectrum of a 4-Hz pure tone acoustically presented at a loudness level of 40 phon through a RadioEar DD45 transducer (top panel, red curve) and through a Beyerdynamic DT48 transducer (bottom panel, black curve). In addition, the threshold in quiet and the 40-phon equal-loudness-level contours (ELLC) are shown (green lines). The top panel also includes a spectrum when no stimulus was presented (blue curve).

3.2 Combination of infrasound and audio sound

Figure 4 shows spectra of a 4-Hz pure tone combined with a 31.5-Hz pure tone, both at a loudness level of 40 phon. The top panels show the spectra when they are presented with the DD45 transducers (red curves). The bottom panels show the spectra when the DT48 transducers are used for stimulus presentation (black curves). In order to test the necessity of separate transducers, one for each pure tone (as commonly used), the combined sound was also presented through a single transducer. The left panels show the spectra when each of the two sounds is presented through a different earphone, the right panels show the spectra when the same earphone is used for simultaneous presentation of the two sounds. As in Figure 3, thresholds and 40-phon equal-loudness-level contours are shown (2; 7).

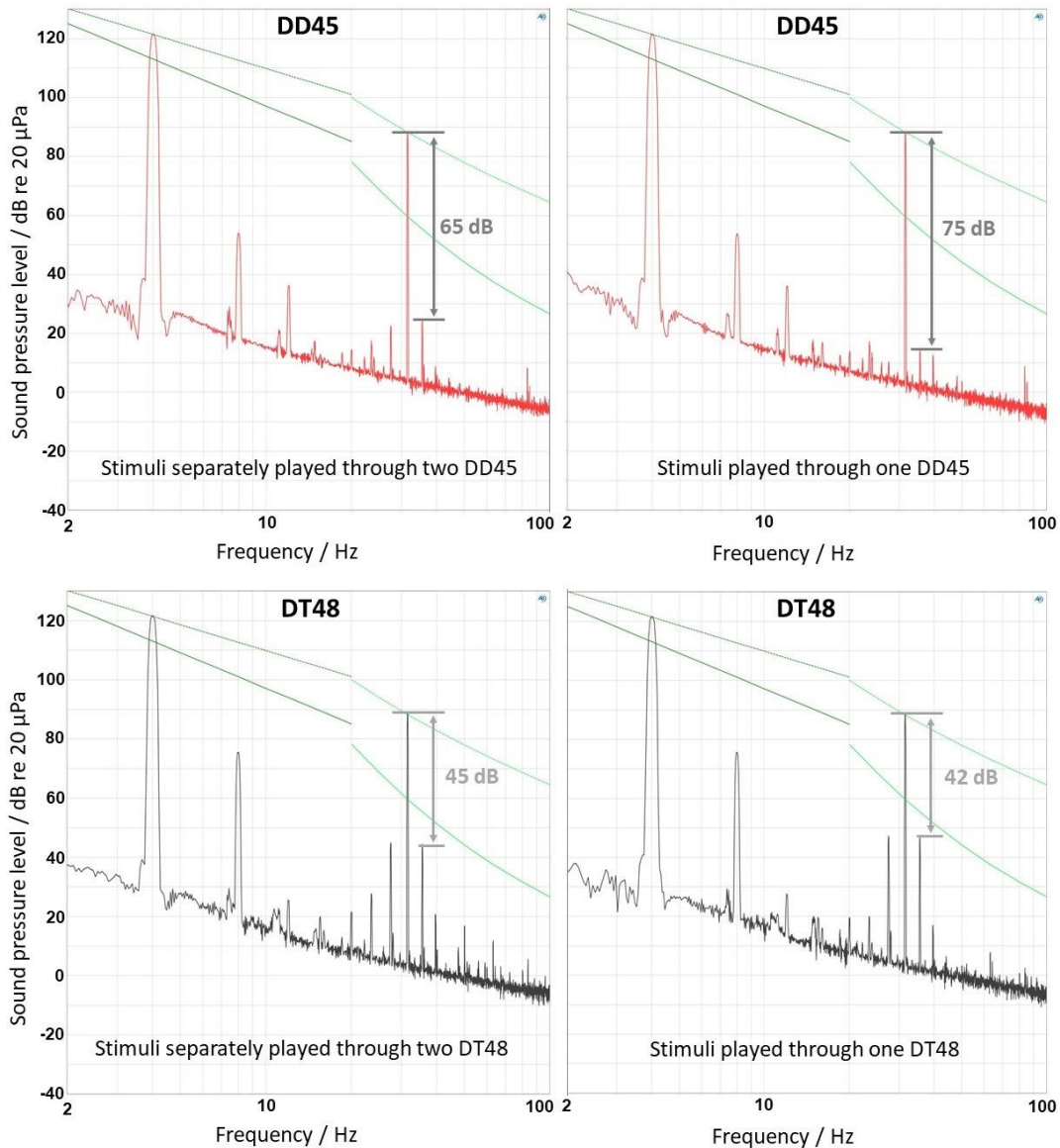

Figure 4 – Spectrum of a 4-Hz pure tone and a 31.5-Hz pure tone, both acoustically presented at a loudness level of 40 phon through RadioEar DD45 transducers (top panels, red curve) and through Beyerdynamic DT48 transducers (bottom panels, black curve). The left panels show the spectra when each pure tone is presented through a different transducer, the right panels show the spectra when the same transducer is used for the simultaneous presentation of both pure tones. Thresholds and equal-loudness-level contours are also shown (green lines, see Figure 3).

When the 4-Hz infrasound and the 31.5-Hz audio sound are presented with different DD45 transducers (left top panel), the audio signal is modulated by the infrasound signal: Side lines with a 4-Hz spacing around the 31.5-Hz line appear. Note that the levels of the side lines are more than 65 dB lower than the level of the 31.5-Hz component.

The DT48 transducers produce side lines that are 20 dB higher than those of the DD45 (left bottom panel). In addition, side lines at multiples of 4 Hz occur around 31.5 Hz. Nevertheless, in both cases the modulation of the audio-signal should not be audible, since at this modulation rate, the levels of the side lines at modulation detection threshold (8) are at least several dB higher than those produced by the non-linearity of the sound reproduction system. Thus, the modulation produced by the system should be inaudible.

If the two sounds are presented with the same transducer, the DT48 shows an increase in the distortions, as expected (bottom right panel). For the DD45 (upper panels), the level differences between the 31.5-Hz component and its side lines were larger when only one DD45 transducer was used ($\Delta L = 75$ dB) as compared to when two DD45 transducers were used ($\Delta L = 65$ dB).

In summary, for the presentation of two tones, the DD45 is more suitable than the DT48. In the case of using two earphone transducers to present two tones separately from each other, the DD45 emitting the audio signal is less sensitive to the infrasound signal, emitted by the second transducer of the same type, than the DT48. Unexpectedly and in contrast to the DT48, a single DD45 transducer, playing both tones together, results in fewer distortions than playing the tones using separate DD45 transducers. That offers the possibility of using a single DD45 transducer for the presentation of stimuli that are more complex than a single sinusoid.

3.3 Characterization of the Etymotic ER-10B+ microphone system

Figure 5 shows the transfer characteristics of the sound reproduction system in conjunction with the Etymotic ER-10B+ microphone probe (blue curve) and the occluded-ear simulator B&K 4157 (red curve), recorded with the setup described in Section 2.3. Both curves were measured simultaneously as sound pressure level against frequency at a constant earphone transducer driving voltage of 0.8 V. Both the ear simulator and the probe microphone have been calibrated by means of a sound calibrator B&K 4131 at 1000 Hz to provide a reading in dB re 20 μ Pa.

From 150 Hz to 1000 Hz, the curves are almost identical, above 1000 Hz they begin to slowly diverge, but are still very similar. The ripple results from sound tube resonances and does not have any undue effect for our purposes. Below 150 Hz, the sound pressure level measured by the Etymotic ER-10B+ microphone probe shows a considerable drop-off towards lower frequencies. The difference to the 'true' value measured by the ear simulator microphone reaches a value of about 40 dB at 3 Hz. By using the difference of both curves, however, the output of the Etymotic ER-10B+ microphone system can be easily equalized to get the 'true' SPL values.

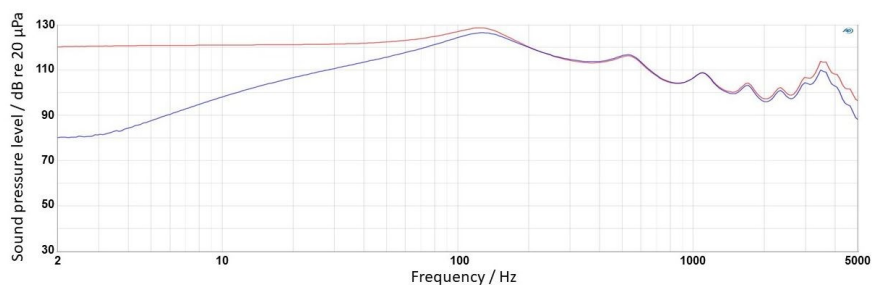

Figure 5 – Sound pressure level produced by the sound reproduction system in the occluded-ear simulator B&K 4157 (red) and measured by the microphone probe of the Etymotic ER-10B+ (blue) when driven by a constant driving voltage of 0.8 V.

Figure 6 shows spectra of a 4-Hz 40-phon pure tone produced by the sound reproduction system in the occluded-ear simulator B&K 4157. The red curve shows the spectrum measured with the ear simulator microphone. The blue curve shows that measured with the Etymotic ER-10B+ microphone probe that has been equalized as described above. The ER-10B+ has slightly lower noise levels as compared to the ear simulator microphone from about 400 Hz to 4000 Hz, but the noise has essentially

the same order of magnitude in both devices. Below 150 Hz, the spectrum measured with the ER-10B+ microphone probe shows higher background noise levels than that recorded with the ear simulator microphone. At 3 Hz, it is about 20 dB higher for the ear simulator microphone. This results from the equalization gain needed for compensating the low-frequency drop-off of the probe microphone. Nevertheless, the 4-Hz pure tone and its higher harmonics are clearly visible, and no additional components are added due to any non-linearities of the ER-10B+ microphone probe. The microphone is not overloaded by the high infrasound pressure level, i.e. it is possible to measure audio sound while high-level infrasound is present in the ear canal. Although the background noise level of the ER-10B+ microphone probe in the lower frequency range is not as low as that of the ear simulator microphone, the ER-10B+ sensitivity seems to be high enough to detect signals with low sound pressure levels, for example infrasound-generated distortion products. Bearing in mind that measurements seeking for the latter in the ear canal will be made in real human ears with their inherent physiological noise, the microphone probe performs really promising.

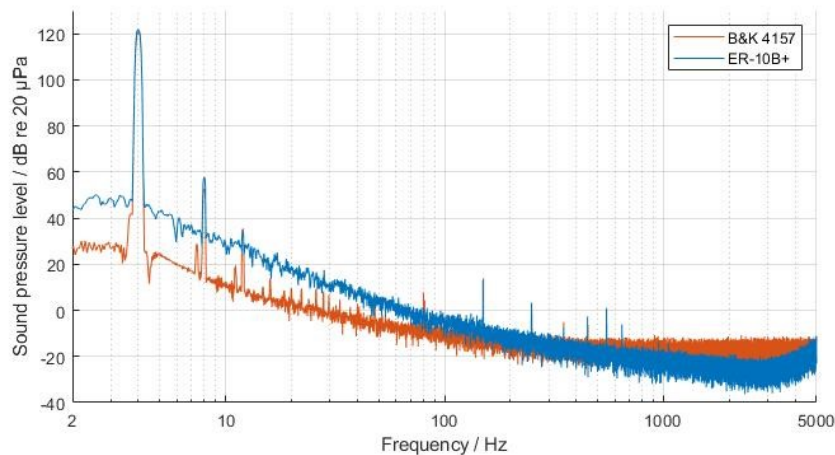

Figure 6 – Spectrum of a 4-Hz pure tone presented at a loudness level of 40 phon measured with the ER-10B+ microphone probe (equalized, blue) and with the occluded-ear simulator B&K 4157 (red).

4. SUMMARY AND CONCLUSIONS

A sound reproduction system was presented that consisted of two RadioEar DD45 audiometric earphone transducers connected to an Etymotic ER-10B+ system with integrated low-noise microphone. It was shown that the system (a) generates sufficiently high sound pressure levels, (b) has distortion product levels well below the respective hearing threshold levels, and (c) enables one, by means of an incorporated low-noise microphone, to monitor the sound and to detect possible distortions directly within the ear. The system can be used to present sound signals with frequencies ranging from 4 Hz to 5 kHz with loudness levels of up to 40 phon. The levels of the harmonic distortions were more than 45 dB below the hearing threshold. It was also shown that the RadioEar DD45 outperformed the often used Beyerdynamic DT48, no matter if stimuli comprising a single infrasound, two infrasounds, or an infrasound and an audio sound are played. Noticeably, a single DD45 transducer, for a signal combining infrasound with audio sound, performs better than two DD45 transducers, which play the two sounds separately. This opens up more possibilities of playing combined signals with the two-transducer system. The ER-10B+ microphone probe could be used to measure sound in the ear canal even while high-level infrasound as low as 4 Hz at a loudness level of up to 40 phon was presented. In the spectrum, the infrasound component and its upper harmonics were clearly visible without distorting components of the microphone probe itself. Altogether, the system can be used in psychophysical experiments on infrasound perception.

ACKNOWLEDGEMENTS

This work was supported by the German Research Foundation (Deutsche Forschungsgemeinschaft, DFG) (FE 1192/3-1 and VE373/4-1).

REFERENCES

1. E DIN 45680:2013: Messung und Beurteilung tieffrequenter Geräuschemissionen. Berlin: Beuth; 2013.
2. Moeller, H.; Pedersen, CS. Hearing at low and infrasonic frequencies. *Noise Health*. 2004;6(23):37–57.
3. Kuehler, R.; Fedtke, T.; Hensel, J. Infrasonic and low-frequency insert earphone hearing threshold. *J Acoust Soc Am*. 2015;137(4):EL347–EL353.
4. Zwicker, E. Masking-period patterns produced by very-low-frequency maskers and their possible relation to basilar-membrane displacement. *J Acoust Soc Am*. 61(4):1031–1040; 1977.
5. Hirschfelder, A; et al. Diagnostik des endolymphatischen Hydrops mit tiefenmodulierten DPOAE. *HNO* 7:612-617; 2005.
6. Kemp, DT. Stimulated acoustic emissions from within the human auditory system. *J Acoust Soc Am*. 64(5): 1386–1391; 1978.
7. ISO 226:2003: Acoustics – Normal equal-loudness-level contours. International Organization for Standardization, Geneva, Switzerland.
8. Kohlrausch, A.; Fassel, R.; Dau, T. The influence of carrier level and frequency on modulation and beat-detection thresholds for sinusoidal carriers. *J Acoust Soc Am*. 108(2):723–734; 2000.